



DIGITAL INDICATOR CONTROLLER

MODEL SC-H50

Features

Compact multi-purpose controller for accurate control of temperature, pressure, flow and level. Ideal for equipment automation and systems creation in many fields.

1. High measurement accuracy of 0.1% F.S.
2. Two target settings can be stored in memory.
3. Uses auto-tuning calculation method for excellent stability and responsiveness.
4. Bar graph shows output status and deviation from setpoint.
5. Allows the addition of alarm output, transmission output and/or remote operation as well as computer communication.
6. With overshoot prevention by a new PID algorithm control.
7. Rated voltage free between 100 and 240V AC.
8. Conforms with CE marking.



Dimensions

Units : mm

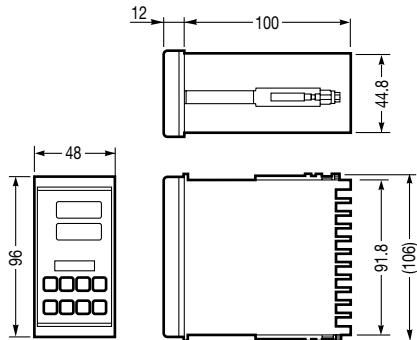

● Panel Cutout and Spacing

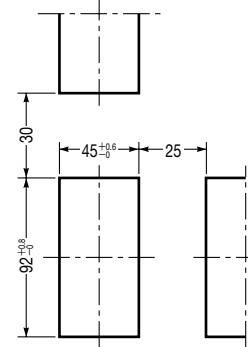

Wiring Terminals

No.	Function
1	GND Ground
2	100 - 240V AC Power
3	
4	COM Relay contact output
5	AL1 Alarm 1 Relay contact output
6	AL2 Alarm 2
7	Control output (OUT2) Analog output
8	① Relay contact output ② Voltage/current output ③ Voltage/current output
9	Control output (OUT1)
10	① Relay contact output ② Voltage/current output ③ Triac trigger output
11	

No.	Function
12	Communications ① RS-232C ② RS-485 ③ RS-422A
13	DI Contact input
14	FBR (Y input)
15	
16	
17	Remote analog setting input
18	CT Heater break current sensor
19	① RTD ② Thermocouple ③ Voltage (Low) ④ Current/Voltage (High)
20	
21	

Specifications

	Item	Description	
Input Signal	Input Signal Type (See next page for ranges)	Thermocouple [Signal Type] K (JIS/IEC), J (JIS/IEC), T (JIS/IEC) E (JIS/IEC), R (JIS/IEC), S (JIS/IEC) B (JIS/IEC), N (NBS), L (DIN), U (DIN) PLI (NBS), W5Re/W26Re (ASTM)	
		RTD Pt100 (JIS/IEC/DIN) JPt100 (JIS)	
	Voltage (LOW) (HIGH)	0 - 10mV, 0 - 100mV, 0 - 1V 0 - 5V, 0 - 10V, 1 - 5V	
	Current	0 - 20mA, 4 - 20mA	
	Measurement Accuracy	± (0.1% F.S. +1digit)	
	Sampling Period	250mSEC	
Display	Data Displayed	<ul style="list-style-type: none"> • Measurement value • Target set value • Deviation or operation output level meter • Alarm/control output status 	
	Measurement/Setting Display	Double-row 4-digit, 7 segment LED	
	Indicator/Setting Accuracy	Same as measurement accuracy	
Control Output	Control Action Types	<ul style="list-style-type: none"> • Two-position (ON/OFF relay) • PID action with auto tuning • Position proportional PID • Heating/Cooling PID action 	
	Kind	Relay Output	1c contact 250V AC, 3A (resistance load) 1a contact at cooling side when Heating/Cooling PID action
		Current Output	4 - 20mA DC, 0 - 20mA DC (allowable load resistance 600Ω maximum)
		Voltage Output	0 - 5V DC, 0 - 10V DC, 1 - 5V DC (allowable load resistance 1kΩ minimum)
		Voltage Pulse Output	0/12V DC (allowable load resistance 600Ω minimum)
		Triac Trigger Output	Zero-cross method. Effective ON current: 50mA (50°C), 70mA (25°C)
	Auto-tuning	Available (3 response speeds selectable: slow, medium, fast)	
	Change Rate Limiter	0.1 - 100.0% variable (OFF at 0)	
	Proportional Band (P)	0.1 - 999.9% (0 setting not possible)	
	Integral Time (I)	1 - 3600 seconds (0 setting not possible)	
Derivative Time (D)	1 - 3600 seconds (PI action at 0)		
Target Setting	Number of Target Settings	2 (preset in memory)	
	Memory Area External Selection	Possible (Non voltage contact input)	
	Remote Analog Setting	Possible	
Alarm	Output Points	2 1a relay contact outputs/250V AC, 1A (resistance load)	
	Types of Alarm	Upper limit, lower limit, upper limit deviation, lower limit deviation, upper/lower limit deviation, etc. (standby function availability can be selected)	
Communications	Optional		
	Output Points	1	
	Output Types	Selectable 1 from measured value, set value, deviation, control output	
	Communications method	RS-422A, RS-485, RS-232C selectable as option	
	Communications speeds	1200, 2400, 4800, 9600, 19200 Bps	
	Communications code	JIS (ASCII) 7-bit code	
General	Voltage	Free between 100 - 240V AC (50/60Hz)	
	Power Consumption	12VA max.	
	Withstand Voltage	Between power terminal and ground: 1500V AC for 1 minute Between measurement terminal and ground: 1000V AC for 1 minute	
	Insulation Resistance	Between power terminal and ground: 500V DC/20MΩ minimum Between measurement terminal and ground: 500V DC/20MΩ minimum	
	Power Interruption Backup	Lithium battery for memory backup (service life 10 years)	
	Ambient Temperature Range	0 - 50 °C	
	Ambient Humidity Range	45 - 85% RH (non-condensing)	
	Vibration Resistance	0.5G maximum	
	Installation Method	Panel installation	
	Weight	Approximately 310g	
	Material	ABS resin (black)	



To avoid abnormal operation, accidents or serious injury, DO NOT use this product outside of the specification range. Local regulations may restrict use of this product to below the conditions quoted.

Measurement Input Types & Ranges

Input Types		Input Range [°C]	Code	Input Range [°F]	Code	1st and 2nd Alarm Types	
Thermocouple (TC)	Type K (EX-: CA) [JIS/IEC]	-199.9 - 300.0 °C	K08	0.0 - 800.0 °F	KA4	Deviation upper limit	A
		0.0 - 400.0 °C	K09	0 - 2400 °F	KA5	Deviation lower limit	B
		0.0 - 800.0 °C	K10			Deviation upper and lower limits	C
		0 - 1300 °C	K11			Within deviation range	D
	Type J (EX-: IC) [JIS/IEC]	-199.9 - 300.0 °C	J07	0.0 - 700.0 °F	JA4	Deviation upper limit w. standby	E
		0.0 - 400.0 °C	J08	0 - 2100 °F	JA5	Deviation lower limit w. standby	F
		0.0 - 800.0 °C	J09			Deviation upper/lower limits w. standby	G
		0 - 1200 °C	J06			Measurement upper limit	H
	Type T (EX-: CC) [JIS/IEC]	-199.9 - 300.0 °C	T05	-199.9 - 400.0 °F	TA6	Measurement lower limit	J
		0.0 - 400.0 °C	T06	0.0 - 700.0 °F	TA7	Measurement upper limit w. standby	K
	Type E (EX-: CRC) [JIS/IEC]	0.0 - 700.0 °C	E03	0 - 1800 °F	EA3	Measurement lower limit w. standby	L
		0 - 1000 °C	E02			FAIL status, control error	M
Type R [JIS/IEC]	0 - 1700 °C	R03	0 - 3200 °F	RA1	Heater break (for 30 A)	P	
Type S [JIS/IEC]	0 - 1700 °C	S03	0 - 3200 °F	SA1	Heater break (for 100 A)	S	
Type B [JIS/IEC]	0 - 1800 °C	B03	0 - 3300 °F	BA3	No alarm	N	
Type N [NBS]	0 - 1300 °C	N02	0 - 2300 °F	NA1	* Heater Break Alarm is selectable only for the 2nd Alarm.		
Type L [DIN]	0.0 - 400.0 °C 0.0 - 900.0 °C	L03 L04	0 - 1600 °F	LA2	* Type and Alarm is selectable by parameter.		
Type U [DIN]	0.0 - 600.0 °C	U04	0 - 1100 °F	UA4			
Type PLII [NBS]	0 - 1300 °C	A01	0 - 2300 °F	AA3			
Type W5Re/W26Re [ASTM]	0 - 2300 °C	W03	0 - 4200 °F	WA2			
RTD	Pt100 [JIS/IEC]	-100.0 - 100.0 °C	D04	-150.0 - 200.0 °F	DB1		
		-199.9 - 600.0 °C	D12	-199.9 - 999.9 °F	DB3		
	JPt100 [JIS]	-100.0 - 100.0 °C	P04	-150.0 - 200.0 °F	PB1		
		-199.9 - 500.0 °C	P11	-199.9 - 900.0 °F	PB2		
Voltage (LOW)	0 - 10mV	0.0 - 100.0%	101	/			
	0 - 100mV	0.0 - 100.0%	201				
	0 - 1 V	0.0 - 100.0%	301				
Voltage (HIGH)	0 - 5 V	0.0 - 100.0%	401				
	0 - 10 V	0.0 - 100.0%	501				
	1 - 5 V	0.0 - 100.0%	601				
Current	0 - 20mA	0.0 - 100.0%	701				
	4 - 20mA	0.0 - 100.0%	801				

Types of Remote Analog Setting Input		
Voltage (LOW)	None	N
	0 - 10mV	1
	0 - 100mV	2
Voltage (HIGH)	0 - 1 V	3
	0 - 5 V	4
	0 - 10 V	5
Current	1 - 5 V	6
	0 - 20mA	7
	4 - 20mA	8

Contact Input Type	
None	N
Memory Area Switch	1
AUT/MAN Switch	2
REM/LOC Switch	3

Analog Transmission Output Type		
Voltage (LOW)	None	N
	0 - 10mV	1
	0 - 100mV	2
Voltage (HIGH)	0 - 1 V	3
	0 - 5 V	4
	0 - 10 V	5
Current	1 - 5 V	6
	0 - 20mA	7
	4 - 20mA	8

* The internal hardware configuration has 3 types.

①: Temperature Input (TC + RTD)

②: Voltage Input (Voltage [HIGH] + Voltage [LOW]) } Voltage [LOW] can be used in both.

③: Current Input (Current + Voltage [LOW])

Within each group, the Input Type and Range can be changed by Parameter.

* The range of Voltage [HIGH and LOW] and Current Input can be changed freely.
Factory setting is 0.0 - 100.0%.

* The above Analog Transmission can be selected only for ON-OFF & PID action with Auto Tuning.

Specifications Checksheet

		Code										Remarks			
Model	SC-H50		<input type="text"/>	<input type="text"/>	-	<input type="text"/>	*	<input type="text"/>	-	<input type="text"/>	<input type="text"/>	-	<input type="text"/>	For boxes in the "code" section at left, enter the appropriate code from among the specification items below each box.	
	Control Operation Type	<ul style="list-style-type: none"> ● 2-Position (ON-OFF) ● PID action with auto-tuning ● Heating/cooling PID action ● Position proportional PID action 	A											<ul style="list-style-type: none"> ● When [A] is specified only [M, V, G] of Control Output 1 is selectable. ● When [Y] is specified, only [M] of Control Output 1 is selectable. 	
Basic Specifications	Measurement Input Types Ranges [PV]	<ul style="list-style-type: none"> ● Pt100 [-199.9 - 600.0 °C] ● TC K [0.0 - 400.0 °C] ● Current [4 - 20mA] ● Other () 	D12											<ul style="list-style-type: none"> ● See "Measurement Input Types & Ranges" for all types. 	
	Control Output1 [OUT1]	<ul style="list-style-type: none"> ● Relay Contact ● Voltage Pulse ● Triac Trigger ● Voltage [0 - 5V] ● Voltage [0 - 10V] ● Voltage [1 - 5V] ● Current [0 - 20mA] ● Current [4 - 20mA] 	M	V	G									<ul style="list-style-type: none"> ● When ON-OFF [A] Control Operation is specified, only [M, V, G] of Control Output 1 is selectable. ● When Position Proportional PID [Y] of Control Operation is specified, only [M] of Control Output 1 is selectable. 	
	Control Output2 [OUT2]	<ul style="list-style-type: none"> ● None (Alarm Control is A, or Y) ● Relay contact ● Voltage Pulse ● Voltage [0 - 5V] ● Voltage [0 - 10V] ● Voltage [1 - 5V] ● Current [0 - 20mA] ● Current [4 - 20mA] 	Blank	M	V	4	5	6	7	8					<ul style="list-style-type: none"> ● Control Output 2 is selectable only when the Control Operation is Heating/Cooling PID [V]. ● Triac Trigger is not selectable in Control Output 2.
	1st Alarm [AL1]	<ul style="list-style-type: none"> ● None ● Deviation upper limit ● Other () 	N	A										<ul style="list-style-type: none"> ● See "Measurement Input Types & Ranges" for all Alarm types. ● Type of Alarm can be changed after shipment. ● Heater Break Alarm and Remote Setting Input cannot be selected together. 	
	2nd Alarm [AL2]	<ul style="list-style-type: none"> ● None ● Deviation lower limit ● Other () 		N	B										
	Optional Specifications	Remote Setting Input [RSV]	<ul style="list-style-type: none"> ● None ● Current [4 - 20mA] ● Other () 						N	8				<ul style="list-style-type: none"> ● See "Measurement Input Types & Ranges" for all Input Signal types. 	
	Contact Input [EXT]	<ul style="list-style-type: none"> ● None ● REM/LOC Switching (1 contact) ● Other () 							N	3			<ul style="list-style-type: none"> ● See "Measurement Input Types & Ranges" for all Contact Input types. 		
	Analog Transmission Output [AO]	<ul style="list-style-type: none"> ● None ● Current [4 - 20mA] ● Other () 							N	8			<ul style="list-style-type: none"> ● See "Measurement Input Types & Ranges" for all Analog Transmission Output types. 		
	Communication [COM]	<ul style="list-style-type: none"> ● None ● RS-232C ● RS-422A (4 wires) ● RS-485 (2 wires) 									N	1	<ul style="list-style-type: none"> ● When Communication is specified, neither Control Operation [Y] nor Contact Input can be selected. 		
Remarks															